

easySCOPE MT DS

Dimensions

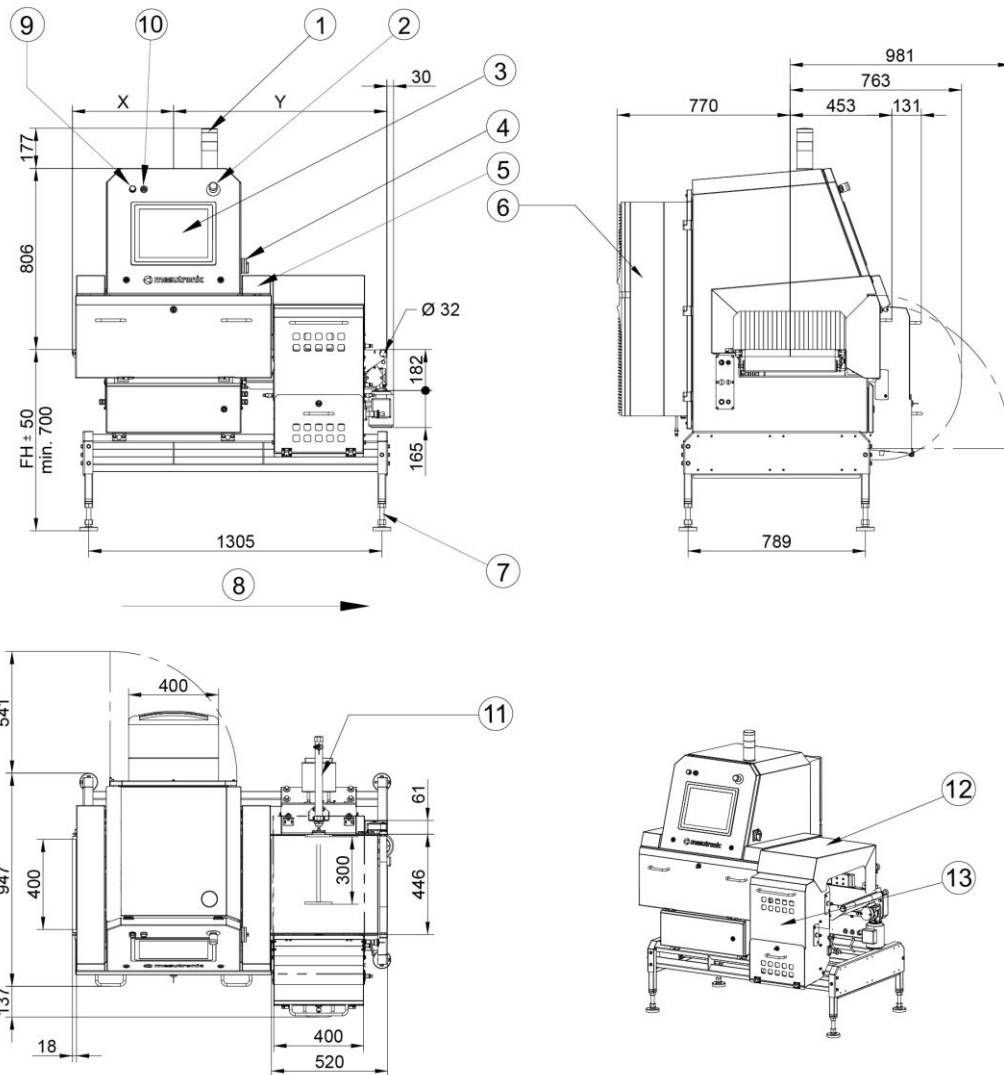

All dimensions in [mm]

- | | | |
|------------------------|--|--|
| 1 Signal tower | 6 Air conditioning unit | 10 USB jack |
| 2 Emergency off switch | 7 Adjustable feet (optional: swivel castors) | 11 Optional: Separation system (pusher, over-belt pusher or blower nozzle) |
| 3 Operating panel | 8 Conveying direction | 12 Optional: Protective cover |
| 4 Main switch | 9 Key switch (X-ray operation) tunnel | 13 Optional: Collecting container - folding |

Conveying length (X, Y)										
X	450	550	650	750	850	950	1050	1150	1250 **	
Y	450	550	650	750	850	950 *	1050	1150	1250 **	

* Minimum length with separation unit – position of the separation system is variable.

** Max. length – longer lengths on request

Conveying height (FH)										
Adjustable feet	700	750	800	850	900	950	1000	1050	1100	1150
Swivel castors (optional)	--	--	--	850	900	950	1000	1050	1100	1150

Note: Deviating conveyor lengths and heights must be agreed with Mesutronic GmbH.

Version 001-01

Mesutronic GmbH

☒ Hackenfeld 13 • 94259 Kirchberg im Wald • Germany

☎ +49 9927 9410 0 • sales@mesutronic.de • www.mesutronic.de

easySCOPE MT DS

Device description

The **easySCOPE MT DS** is a state-of-the-art dual-energy X-ray inspection system with **photon counting technology**. This technology enables precise material separation and therefore reliable detection of even difficult-to-identify foreign objects such as **bones in meat** or **fish**. In addition, metallic and non-metallic foreign objects such as glass, ceramics, stones and plastic are reliably detected. Thanks to high-resolution image processing and intelligent evaluation algorithms, the system achieves maximum detection accuracy and also offers advanced quality checks such as fill level, shape and integrity checks.

The easySCOPE MT DS is designed for food contact in accordance with FDA regulations and is therefore ideal for demanding inspection tasks in the food, pharmaceutical and packaging industries.

Areas of application

The easySCOPE MT DS can be used in both the non-food and food sectors and is used for precise foreign object detection and reliable quality control.

The system is specially designed for demanding applications in the food industry and is suitable for complex product structures such as meat and sausage products, fish products or baked goods. It reliably recognises bones, fish bones and metallic and non-metallic foreign objects – such as glass, ceramics, stones, plastics or metal parts.

Thanks to its hygienic design and easy cleaning, the system fulfils the highest requirements for use in sensitive production environments.

Product specification & ambient conditions

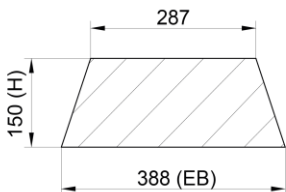
Inspection area	Product dimensions
	<p>Sensitive width (EB) = 388 mm (on belt) – 0.673 x product height (H)</p> <p>Examples of product dimensions (width x height):</p> <p>1) 381 x 10 mm 2) 367 x 30 mm 3) 347 x 60 mm 4) 327 x 90 mm 5) 307 x 120 mm 6) 287 x 150 mm</p>
Product shape	Packaged products
Product length	Max. 200 mm 200 mm to max. 600 mm – <i>on request</i>
Product temperature	-10°C to +70°C
Min. product weight	10 g (application-specific; required for opening the radiation protection curtains) – <i>Product test is recommended</i>
Max. product weight	Approx. 3 kg at 1.5 m/s; 5 kg at 1.2 m/s; 10 kg at 0.6 m/s Conveying speed
Storage and transport conditions	-10°C to +60°C, 0 – 90 % rH
Operating conditions	Ambient temperature +2°C to 35°C (air conditioning unit) Installation site: Interiors Degree of contamination: 2

The throughput capacity depends on product size, weight and conveying speed.
 The detection accuracy is tested on a product-specific basis and depends on the material properties as well as the type, size and position of the foreign object. The detection quality remains consistently high even at high speeds.

easySCOPE MT DS

Functional characteristics

Detection & testing

Foreign object detection	Detection of metallic and non-metallic foreign objects (e.g. glass, ceramics, stones) using intelligent evaluation algorithms. Advanced function: Detection of bones in meat or in fish through material separation.
Quality inspection	Object counting Optional: Weight test, integrity test, clip test
Area management	Edge masking, segmentation Optional: Clip masking
Lane evaluation	Single-lane evaluation (standard) Optional: Evaluation of up to four lanes

Operation & software

Operating system	Windows 11
Operator interface	15" touch display 4:3; tempered glass, capacitive
Multilingual capability	Multilingual user interface

Product & user management

Product management	Storage and management of max. 500 products with individual parameters.
Log book / logging	Max. 100,000 entries
Automatic learning of products	User-friendly configuration of the detection settings with wizards for product learning.
Event / product counter	Display on the display, exportable

Communication

Interfaces	Ethernet (LAN), USB
Communication protocols	OPC UA, XML

Security & system control

Functional test	Software-based detector test and monitoring of device functions
X-ray	Radiation measurement, signal plot
Password protection	Customised access and user management
Test function	Detector test, contamination level, self-diagnosis
Protected against power failure	Settings & data protected against power failure, exportable

easySCOPE MT DS

Device design

X-ray technology

X-ray tubes	Generator – max. 80 kV / 8 mA (350 W)
Receiver	Dual energy – Photon counting: 411 mm
Receiver resolution	0.2 mm
Radiation emission	< 0.5 µSv/h
Radiation protection curtain	Lead-free rubber matrix with reinforcement fabric (blue), FDA approved

Mechanical design

Surfaces / housing	Stainless steel 1.4301 (AISI 304), sandblasted
Construction method	Housing with integrated front flap and conveyor belt
Weight	Approx. 300 kg
Protection class	Housing IP 55 / conveyor belt system IP 65

Conveyor technology

Belt width	400 mm
Roller diameter	Ø 32 mm
Belt material	Thermoplastic polyurethane (TPU), white (optional: blue), smooth, non-adhesive, without studs and corrugated edge - EU / FDA / USDA-compliant
Belt change	Quick-release device for belt
Slide plate	Stainless steel 1.4301 (AISI 304) – satin / polished
Conveying length	900 – 2500 mm (without separation) 1400 – 2500 mm (with separation) <i>- longer lengths on request -</i>
Conveying height	750 – 1250 mm ± 50 mm
Conveying direction	Horizontal: Left–right or right–left
Conveying speed	Up to 1.5 m/s – adjustable for specific applications

Drive and cooling

Motor	Worm gear motor
Cooling	Air conditioning unit

easySCOPE MT DS

Electrical design

Operating voltage	230 V AC +/- 10%, 50/60 Hz; optional: 115 V AC, 60 Hz
Power consumption	Air conditioning unit and dual energy (photon counting): max. 1600 W
Mains cable	3 m cable with Schuko plug
Signalling elements	LED signal light: red, yellow; optional: blue, green, acoustic
Sensors	Entry light barrier, rotary encoder
Controller	PLC, safety controller, frequency converter
Switching inputs and switching outputs	Enable signals for predecessor and successor systems - Further options on request -

Standard scope of delivery

Product inspection system

Conveyor system, radiation protection covers, radiation protection curtains, subframe

Operating instructions with spare parts list and electronic connection diagram

EU Declaration of Conformity:

- 2006/42/EC - Machinery Directive
- 2014/30/EU - EMC Directive
- 2011/65/EU - RoHS Directive
- EC 1907/2006 - REACH - Regulation
- 2013/59/EURATOM – Radiation protection

Versions

- **US package:**
Operating voltage: 115 V AC, 60 Hz
FDA compliant – (21 CFR Part 1020.40, 21 CFR Part 21 1010)
NRTL certification (UL 61010-1, UL 61010-2-091)

Conformity

Optionally available:

- FDA – Contact with food (documentation)
- France: NF C 74-100 & NF C 74-100 ADD 3

easySCOPE MT DS

Options

X-ray technology:

- Lane evaluation for up to four lanes, including associated sensors

Mechanical design:

- Separation system: Pusher | Over-belt pusher | Blower nozzle, including compressed air and function monitoring, Stainless steel collecting container (lockable, hinged) and protective cover
- Swivel castors - Stainless steel 1.4301 (AISI 304)

Electrical design:

- Operating voltage: 115 V AC, 60 Hz

Service / connectivity / confirmation:

- mesuCOMPKIT (sensor package)
- mesuREMOTE (remote maintenance kit)
- mesuLINK (networking software)
- mesuEXPORT (automatic protocol export)
- RFID user authentication

Accessories

Mechanical design:

- Separation system blower nozzle: Additional compressed air tank

Conveyor technology:

- Side guide rails: Stainless steel, inside the radiation protection curtains
- Wear protection: TPU curtain at the infeed of the radiation protection curtains (no food approval)
- Conveyor belt: TPU blue, smooth non-adhesive, without studs and corrugated edge – EU / FDA / USDA-compliant
- Signal tower: Acoustic, green, blue

Software:

- Integrity test, clip test, clip masking, weight test

Miscellaneous:

- Test cards: Various designs and materials on request

© 2025 Mesutronic GmbH. All rights reserved.

This technical data sheet and all of the information, drawings and descriptions it contains are protected by copyright. Transfer to third parties, reproduction, or other use – even in part – is not permitted without the prior written consent of Mesutronic GmbH. Technical changes and errors excepted.

Note:

If you require further product information that goes beyond the content of this technical data sheet and in particular concerns a specific use and the application of this product, please contact us.