

# METAL DETECTOR

## METRON 07 PowerLine

### RELIABLE DETECTION OF ALL METALS:

- FERROUS
- STAINLESS STEEL
- ALUMINUM
- COPPER
- BRASS
- .....

RELIABLE DETECTION OF FREE OR ENCAPSULATED CONTAMINANTS.

Version 08/13



**HIGH-SENSIVITY METAL DETECTOR FOR THE EXAMINATION OF FREE-FLOWING BULK MATERIALS IN PNEUMATIC CONVEYING PIPES AND IN FREE FALL.**

### INDUSTRIES

- FOOD INDUSTRY
- CHEMICAL / PHARMACEUTICAL INDUSTRY
- ANIMAL FOOD INDUSTRY
- PLASTIC INDUSTRY
- ....

### APPLICATIONS

- QUALITY INSPECTION (TO MEET THE REQUIREMENT OF ISO 9000, HACCP, IFS, BRC, SQF, ...)
- MACHINERY PROTECTION

THE INTEGRATED SIGNAL PROCESSOR (DSP) IS THE PRECONDITION FOR DIGITAL, 2 CHANNEL SIGNAL PROCESSING, EVEN WITH CONVEYING SPEEDS AS HIGH AS 30 METERS/SEC.

[www.mesutronic.de](http://www.mesutronic.de)

# MESUTRONIC

*Metal Detection made in Germany*

## STANDARD SCOPE OF DELIVERY

- DETECTOR HEAD WITH INTEGRAL CONTROL ELECTRONICS
- CONTROL UNIT INCL. POWER SUPPLY AND DISPLAY IN SEPARATE HOUSING
- POWER SUPPLY CORD AND CONNECTING CABLE
- USER MANUAL INCL. INSTALLATION INSTRUCTIONS, WIRING DIAGRAM AND SPARE PARTS LIST IN SEVERAL LANGUAGES
- EC CONFORMITY DECLARATION

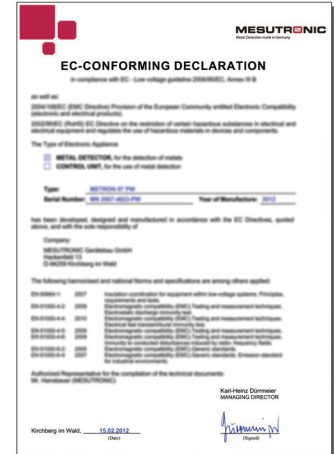

## OPTIONAL EQUIPMENT

- METAL DETECTOR-TEST SPHERES
  - METAL SPHERE(S) ENCASED IN PLASTIC TO VERIFY SENSITIVITY
  - SEVERAL SIZES AND TYPES – (IF DESIRED WITH CERTIFICATE)
- WARNING DEVICE
  - BEACON
  - BUZZER
  - BEACON WITH SIREN
- WIFI
  - COMMUNICATION MODULE FOR WIRELESS CONNECTION ONTO NETWORKS
- SOFTWARE SOLUTIONS
  - mesuNET (NETWORK INTEGRATION AND REMOTE MAINTENANCE)
- REMOTE RESET BUTTON

## SPECIAL VERSIONS

- EXPLOSION PROOF VERSION
- CUSTOM PAINT
- SPECIAL POWER SUPPLY
- ALUTRON-VERSION (SUPPRESSION OF INTERFERENCE SIGNALS FROM METALISED FOILS OR ALUMINIUM VAPOR FOILS)



# DIMENSIONS

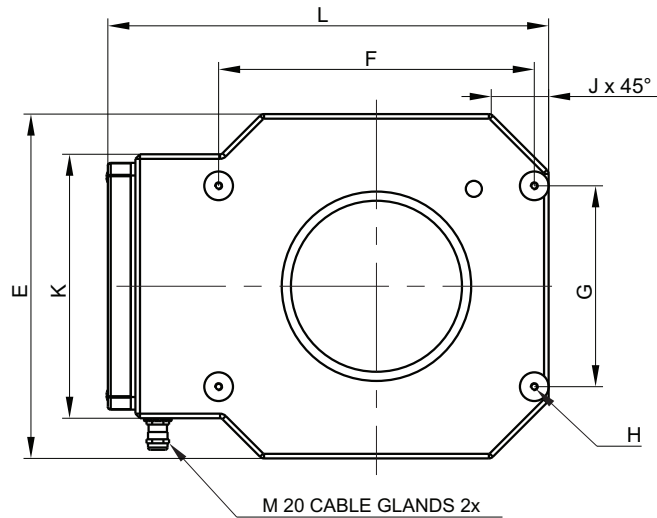

ELECTRONIC BOX  
WEIGHT APPROX. 6 KG  
(DRILLING PATTERN)

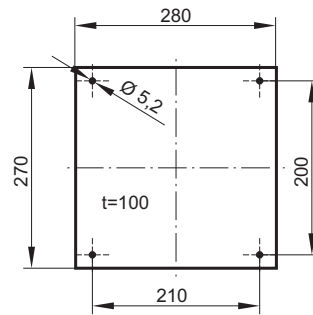

DETAIL Z

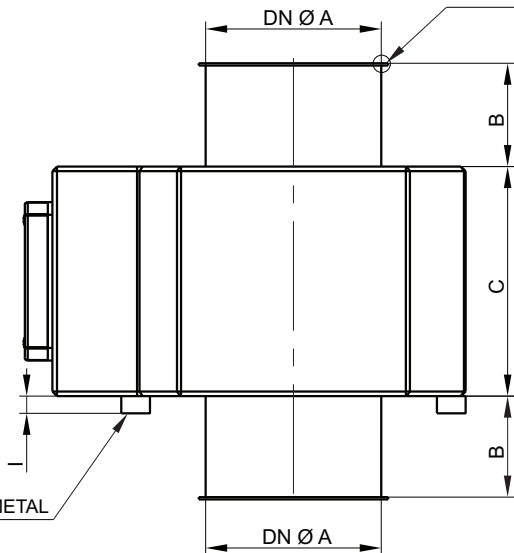

DETAIL Z

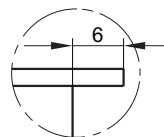

SYSTEM JACOB  
2x DN 60 - 300

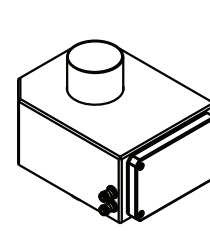

DN 50

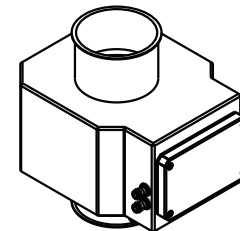

DN 150 - DN 200

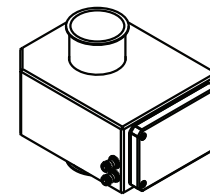

DN 60 - DN 120

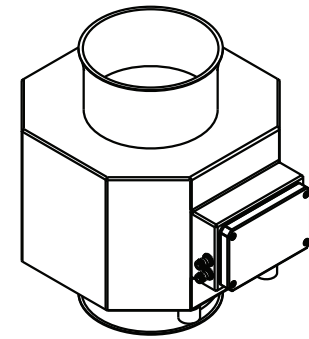

DN 250 - DN 300

DN ØA	B	C	E	F	G	H	I	J	K	L	WEIGHT APP.
50	50	150	230	175	115	M6	15	45	230	274	16 kg
60	42	150	230	175	115	M6	15	45	230	274	19 kg
80	42	150	230	175	115	M6	15	45	230	289	22 kg
100	73	150	250	225	125	M6	15	50	250	339	25 kg
120	80	150	250	225	125	M6	15	50	250	339	28 kg
150	90	200	300	275	175	M6	15	50	230	384	30 kg
200	100	250	365	310	170	M8	30	88	230	451	35 kg
250	125	300	450	400	200	M8	30	115	230	534	40 kg
300	150	350	550	500	205	M8	30	160	230	634	45 kg

ALL DIMENSIONS IN MM.  
OTHER VERSIONS ON REQUEST.

## METAL FREE ZONE (MFZ)



TUBING, HOPPERS OR CONNECTING FLANGES MADE FROM METAL CAN BE DIRECTLY CONNECTED TO THE DETECTOR COIL (FOR EXAMPLE WITH A QUICK CONNECT CLAMP). A METAL-FREE ZONE IS NOT REQUIRED IN THIS CASE.

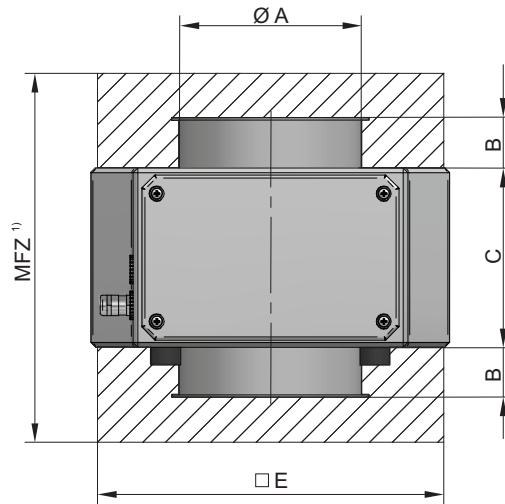

### CALCULATING THE "METAL FREE ZONE" DN 50 - DN 200

FOR MOVING METALS

$$MFZ = 2 \times B + C + 50 \text{ MM}$$

### CALCULATING THE "METAL FREE ZONE" DN 250 - DN 300

FOR MOVING METALS

$$MFZ = 2 \times B + C + 100 \text{ mm}$$

<sup>1)</sup> POSITION THE DETECTOR IN THE MIDDLE OF THE „METAL FREE ZONE“  
FOR THE OTHER DIMENSIONS: POSITION THE DETECTOR SYMMETRICAL IN RELATION TO THE APERTURE.

THE CALCULATED DIMENSIONS ARE TO BE TAKEN AS ORIENTATION VALUES (MINIMUM VALUES WHICH CAN BE EXCEEDED.) AND HAVE TO BE VERIFIED BY THE MANUFACTURER, DEPENDING ON THE PROJECT. MAKE THE „METAL FREE“ ZONE AS LARGE AS POSSIBLE. „NON-MOVING METALS“ ARE, FOR EXAMPLE, CONVEYOR FRAMES AND COIL CONSOLES. „MOVING METALS“ ARE ROLLS OR AXLES. PAY PARTICULAR ATTENTION TO MOVING GATES AND MACHINES OR MACHINE PARTS WHICH CHANGE THEIR DISTANCE TO THE METAL DETECTOR OR WHICH MOVE IN THE VICINITY OF THE APERTURE. IF THE METAL FREE ZONE CANNOT BE MAINTAINED DUE TO SPACE RESTRICTIONS FALSE REJECTS AND OR REDUCED SENSITIVITY CAN BE EXPECTED.

IN ADDITION, PLEASE OBSERVE OUR „ HINTS FOR THE INSTALLATION OF SEARCH COILS“

## SENSITIVITY

DETECTOR NOMINAL DIAMETER $\varnothing A$	50	60	80	100	120	150	200	250	300
SENSITIVITY <sup>1)</sup> STEEL-BALL $\varnothing$ MM	0,25	0,3	0,4	0,5	0,6	0,7	0,8	1,0	1,2

<sup>1)</sup>THE SENSITIVITY IS PROPORTIONAL TO THE DIAMETER OF THE APERTURE. THE SMALLER THE APERTURE, THE HIGHER THE SENSITIVITY. THE ABOVE STATED VALUES WERE OBTAINED IN THE CENTRE OF THE APERTURE UNDER SIMULATED PRODUCTION CONDITIONS AND ARE VALID FOR MOST DRY POWDERS AND GRANULATES.

MAXIMUM OBTAINABLE SENSITIVITY VALUES CAN BE ESTABLISHED BY TESTING YOUR PRODUCT SAMPLE IN OUR LABORATORY.

SENSITIVITY VALUES FOR OTHER MATERIALS:

STAINLESS STEEL: FE SPHERE x 1,0 UP TO 2,0  
(DEPENDENT ON THE ALLOY)

NON-FERROUS MATERIALS SUCH AS BRONZE, COPPER, ALUMINUM: FE SPHERE x 1,0 UP TO 1,8  
(DEPENDENT ON THE TYPE OF METAL).

### ALTERNATIVE FOR INSTALLATION IN CONFINED SPACES

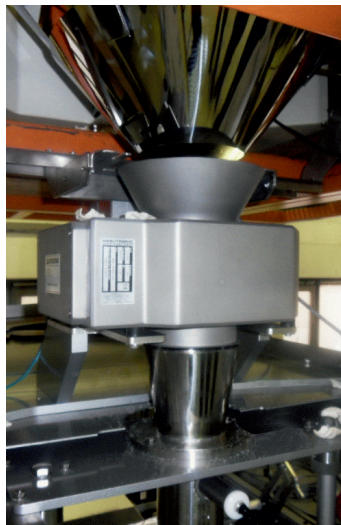

METAL DETECTOR METRON 05 FlatLine  
MOUNTED BETWEEN MULTHEAD WEIGHERS  
AND VERTICAL BAG FILLERS.

## CONTROL UNIT AMD 07

ADVANTAGES THAT WILL CONVINCE YOU!

**UNLIMITED FLEXIBILITY** DUE TO NETWORK-ENABLED SYSTEM COMPONENTS. THE METAL SENSOR, THE DISPLAY AND THE CONTROL UNIT COMMUNICATE VIA ETHERNET AND CAN BE COMBINED AS REQUIRED. SOME COMPONENTS MAY NOT BE REQUIRED, IF THE METAL DETECTOR IS INTEGRATED IN OTHER MACHINERY DISTANCES ARE IRRELEVANT. HIGHEST SENSITIVITY AND AVAILABILITY ARE GUARANTEED.

**AUTO-SETUP-ROUTINE** WITH INTERFERENCE SIGNAL SUPPRESSION AND AUTOMATIC SENSITIVITY CALIBRATION.

**AUTOMATIC PRODUCT-EFFECT CANCELLATION** WITH REAL TIME PRODUCT PARAMETER MEASUREMENT CAPABILITIES.

**DYNAMIC AUTO-TRACKING** (PRODUCT CHARACTERISTIC CHANGE TRACKING) GUARANTEES MAXIMUM SENSITIVITY IN OPERATION.

**MULTI-FILTER SYSTEM** USING DIGITAL FILTERS FOR MAXIMUM STABILITY IN HARSH ENVIRONMENTS.

**AUTO-BALANCE** AUTOMATICALLY DETECTS AND COMPENSATES FOR ANY CHANGES IN THE SIGNAL DURING NORMAL OPERATION. (E.G. TEMPERATURE VARIATIONS)

**TOUCH SCREEN CONTROL PANEL** – MAXIMUM INFORMATION, EASY AND FAST OPERATION! THE 5,7" BACKLIT VGA COLOR-TOUCH-DISPLAY IS LARGE ENOUGH TO DISPLAY SUCH INFORMATION AS PARAMETER DATA AND PROTOCOL CONTENTS IN A LEGIBLE MANNER. INPUT FIELDS AND OTHER OPERATING TOOLS HAVE GENEROUS DIMENSIONS AND ARE ERGONOMICALLY ARRANGED. EASY TO OPERATE WITH CLEAR MENUS AND SELECTABLE OPERATING LANGUAGE THE OSCILLOSCOPE FUNCTION MAKES THE SIGNAL WAVES VISIBLE BY PROJECTING THEM ONTO THE DISPLAY!

**3 LEVELS OF USER ACCESS** (INDIVIDUAL PIN CODES UP TO 4 LEVELS) GUARANTEE PROTECTION AGAINST UNAUTHORIZED ACCESS DUE TO INTELLIGENT USER MANAGEMENT. INDIVIDUAL ACCESS FOR AUTHORIZED PERSONNEL WITH PERSONALIZED ACCESS CODE (USER ID) IN ADDITION 2 FREE CONFIGURABLE FUNCTION KEYS.

**METAL COUNTER** CAN BE DISPLAYED ON THE LCD SCREEN OR INTERFACED WITH A PRINTER OVER A SERIAL INTERFACE.

**QUALITY** SMD's (SURFACE MOUNTED DEVICES) ARE USED IN THE PRODUCTION OF THE CONTROLS. THEY NOT ONLY OFFER A COMPACT DESIGN, BUT ALSO PROVIDE HIGHER QUALITY AND MORE ROBUST PERFORMANCE UNDER HARSH CONDITIONS. ALL MESUTRONIC PRODUCTS CONFORM TO THE CE STANDARDS AND ARE DEVELOPED ACCORDING TO TECHNICAL STANDARDS AND NORMS SUCH AS EN, DIN AND UVV.



**METAL DETECTOR NETWORK AND REMOTE SERVICE** EVERYTHING IS POSSIBLE! SEVERAL OPTIONAL SOFTWARE-PACKAGES ARE AVAILABLE. WITH THE AID OF MODERN NETWORK SOLUTIONS SUCH AS ETHERNET OR Wi-Fi YOU CAN ESTABLISH A SECURE AND EFFICIENT DATA MANAGEMENT SYSTEM WITH AN UNLIMITED NUMBER OF DETECTORS. THE UNITS CAN BE REMOTE CONTROLLED VIA A CENTRAL PC. WE CAN ALWAYS BE PRESENT LOCALLY WITH **mesuREMOTE**, THE MESUTRONIC REMOTE SERVICE MODULE.

**SELF MONITORING SYSTEM** ENSURES ALL IMPORTANT COMPONENTS ARE FUNCTIONING PROPERLY. IN CASE OF A FAULT, RELAY OUTPUTS ARE AVAILABLE. FAULTS ARE DISPLAYED AS TEXT IN REAL TIME.

**PRODUCT STORAGE MEMORY BACKUP** FOR UP TO 1000 INDIVIDUAL PRODUCTS. EACH PRODUCT HAS A COMPLETE SET OF SETUP PARAMETERS ASSIGNED, SUCH AS SENSITIVITY, EJECT TIME ETC. THE DISPLAY OF TIME RELEVANT DATA IS IN REAL-TIME. INDIVIDUAL PRODUCT NAMES CAN BE STORED AS WELL.

**DETECTOR TEST FUNCTION** (VALIDATION) YOU MAY CHOOSE BETWEEN THE MANUAL OR AUTOMATIC MODE. IN THE AUTOMATIC MODE THE DETECTOR WILL ADVISE AUTOMATICALLY, WHEN THE DETECTOR TEST IS TO BE PERFORMED. THE CYCLE TIME CAN BE ADJUSTED FROM 1 MINUTE TO 11 HOURS IN REAL TIME. THE TEST RESULTS ARE DOCUMENTED IN THE EVENT LOG INCLUDING DATE AND TIME STAMP.

**USB DATA MEDIA** AS MOBILE DATA CARRIER. A USB CONNECTION IS STANDARD EQUIPMENT TO STORE DATA ON A COMMERCIALY AVAILABLE DATA STORAGE MEDIA. MODERN DATA STORAGE DEVICES HAVE SUFFICIENT CAPACITY TO STORE ALL ADJUSTMENT AND PRODUCT PARAMETER DATA AS WELL AS THE RESULTS. IN ADDITION SOFTWARE UPDATES AND ADDITIONAL LANGUAGE FILES CAN BE UPLOADED EASILY AND COMFORTABLY.

**MULTI-MODE-FUNCTION** (OPTIONAL) IMPROVES SENSITIVITY IF PRODUCTS IN STANDARD PACKAGING AND METALIZED FOIL PACKING ARE EXAMINED WITH THE SAME METAL DETECTOR. THE DETECTOR SELECTS THE OPTIMAL FREQUENCY AUTOMATICALLY DURING THE PRODUCT PARAMETER MEASUREMENT. ALL PRODUCT SPECIFIC VALUES CAN BE STORED AND CAN BE RETRIEVED IMMEDIATELY AFTER A PRODUCT CHANGE

**DATA PORTS** FOR DIFFERENT TASKS. THE METAL DETECTOR IS EQUIPPED WITH 2 DATA PORTS, WHEREAS ONE OF THE DATA POINTS (ETHERNET) IS RESERVED FOR SERVICE SUCH AS SECURING DATA, LOCAL SOFTWARE UPDATES AND SUCH. THE OTHER DATA POINT (RS232) IS FREELY AVAILABLE. BI-DIRECTIONAL DATA COMMUNICATION WITH CLIENTS SPS OR PC SYSTEMS IS POSSIBLE. (SOFTWARE PACKAGES ARE OPTIONAL).

## CONTROLS

EXAMPLE OF AN INPUT DISPLAY (DEPENDING UPON THE SELECTED MENU THE DISPLAY SHOWS DIFFERENT FUNCTIONS !)

DISPLAY (PRODUCT NAME, BATCH NUMBER, ETC.)

SENSITIVE KEY CONTROL (HERE TO SELECT FOR THE USER LEVELS)

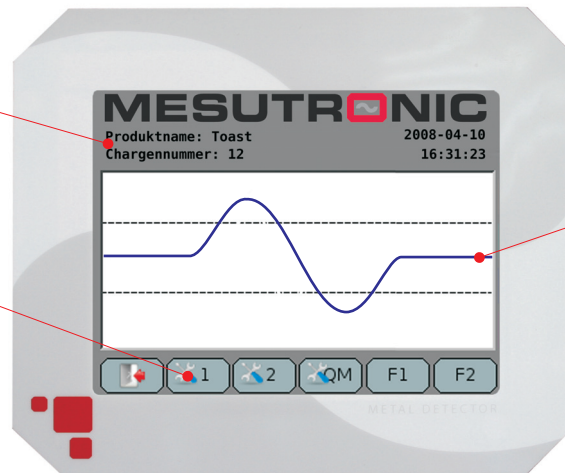

SIGNAL WAVE DISPLAY

5,7" COLOR-TOUCH DISPLAY (320 X 240 PIXEL)

ADAPTER PLATE (PROJECT SPECIFIC ASSIGNABLE WITH ADDITIONAL CABLE CONNECTIONS, BUSHINGS AND SUCH)

USB (A) CONNECTION



POWER CONNECTION

SCREWED CONNECTION FOR THE DETECTION COIL (USED BY THE MANUFACTURER)

CABLE CONNECTION AS NEEDED  
1 x M 20 x 1,5 und 2 x M 16 x 1,5  
1 x M 25 x 1,5

## TECHNICAL DATA

POWER SUPPLY:	100 V - 240 V AC, 50 OR 60 Hz AS SPECIAL VERSION 24 V DC
CURRENT CONSUMPTION:	MAX. 75 W
FUSED:	1,25 A (SLOW BLOW), 5 x 20 MM ACCORDING TO DIN
POWER FUSE:	MAX. 10 A (PROVIDED BY THE CUSTOMER)
TYPE OF PROTECTION:	IP 66
WORKING TEMPERATURE:	- 10° C TO + 50° C
STORAGE TEMPERATURE:	- 10° C TO + 60° C
PRODUCT TEMPERATURE:	MAX. 50° C
RELATIVE HUMIDITY:	0 TO 95 % (WITHOUT CONDENSATION)
IMPULSE LENGTH METAL SIGNAL:	0,1 SEC. TO 30 SEC. (ADJUSTABLE)
FEED PRESSURE:	MAX. +/- 0,5 BAR
VERSION:	DETECTOR HEAD AND ELECTRONIC BOX STAINLESS STEEL (1.4301), SANDBLASTED SENSOR AREA PE (POLYETHYLENE), FOOD GRADE ANTISTATIC, FDA CONFORMITY
POWER CABLE:	APP. 1,8 M CABLE WITH PLUG (TWO POLE AND EARTHING PIN) (US-VERSION WITH US-STANDARD PLUG)

OTHER VERSIONS AVAILABLE

POSITIONS

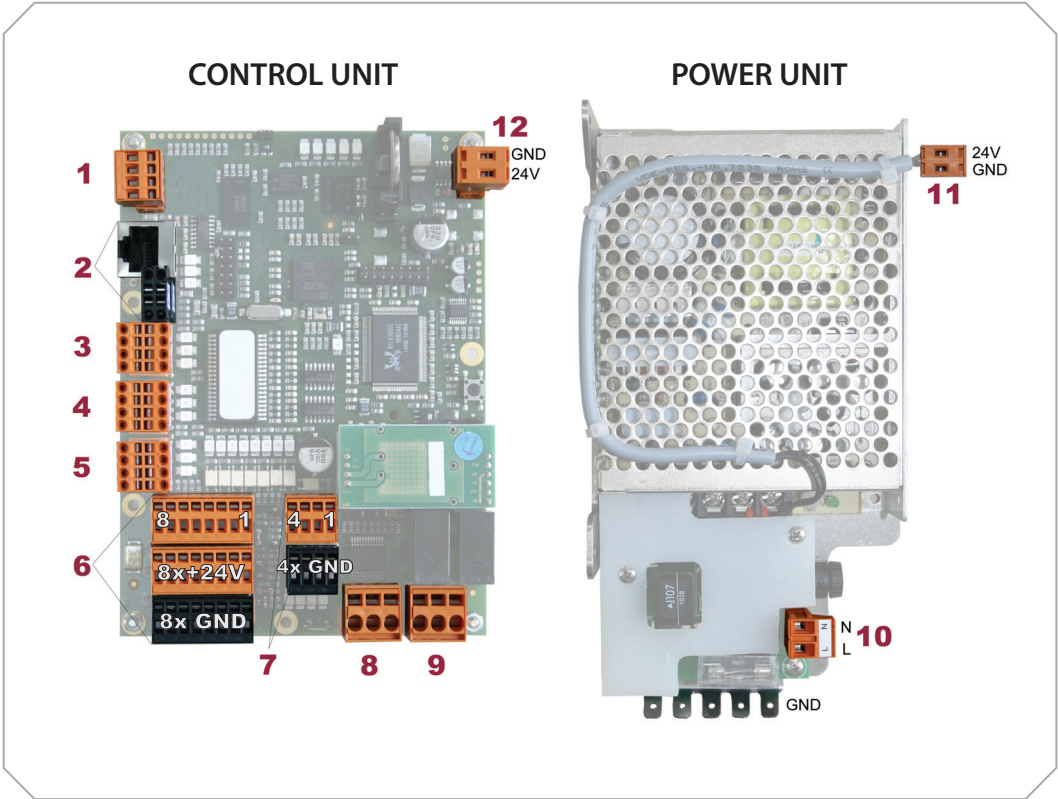

- 1** SERIAL PORT RS 232 (OPTIONAL)
- 2** ETHERNET INTERFACE (USED BY THE MANUFACTURER)
- 3** ETHERNET INTERFACE FOR NETWORK (SUCH AS mesuNET)
- 4** ETHERNET CONNECTION FOR THE SENSOR-UNIT (USED BY THE MANUFACTURER)
- 5** ETHERNET CONNECTION FOR THE DISPLAY-UNIT (USED BY THE MANUFACTURER)
- 6** EIGHT (8) FREE PROGRAMMABLE INPUTS (24V DC)  
 INPUTS (STANDARD LAYOUT)  
 IN 1 - INITIATOR „NORMAL POSITION“ (EJECT GATE)  
 IN 2 - INITIATOR „EJECT POSITION“ (EJECT GATE)  
 IN 3 - PRESSURE MONITOR (PRESSURE SWITCH)  
 IN 4 - OFFLINE SWITCH (DEACTIVATION OF METAL DETECTION)  
 IN 5 - FREE  
 IN 6 - FREE  
 IN 7 - FREE  
 IN 8 - FREE  
 ADDITIONAL CONNECTIONS SUCH AS LIGHT TRIGGERS, FILL SENSORS AND SUCH

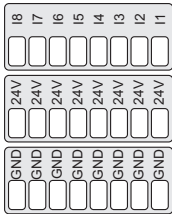

## POSITIONS

### 7 FOUR (4) FREELY PROGRAMMABLE OUTPUTS (24 V DC)

OUTPUT (STANDARD LAYOUT)

OUT1 - METAL

OUT2 - UNIT OPERATIONAL INDICATOR

OUT3 - FREE

OUT4 - FREE

ADDITIONAL CONNECTIONS: MAGNET SOLENOID (EJECT MECHANISM),  
FAULT INDICATOR, ALARM AND SUCH.

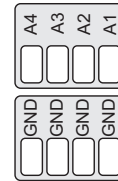

MAX. LOAD FOR ALL INPUTS AND OUTPUTS  $I_{TOTAL} \leq 300 \text{ mA CUMULATIVE!}$

### 8 RELAY 2 (CONNECT AT FAULT)

FLOATING CHANGE OVER CONTACT

ACTUATED BY SELF MONITORING SYSTEM (NORMAL OPERATION)

MAX. CONTACT LOAD: 250 V/3 A

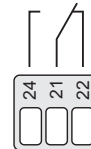

### 9 RELAY 1 (CONNECT WHEN METAL)

FLOATING CHANGE OVER CONTACT ACTUATED WHEN METAL IS DETECTED

MAX. CONTACT LOAD: 250 V/3 A

PULSE DURATION (AUTO-RESET): 0,1 SEC. TO 30 SEC. (ADJUSTABLE)

PULSE DURATION (RESET BY HAND): PERMANENT SIGNAL UNTIL RESET-BUTTON IS  
PRESSED

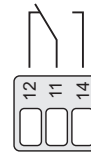

IF REQUIRED THE RELAYS MAY BE PROGRAMMED DIFFERENT.

### 10 POWER CONNECTION

11 24V DC SUPPLY OUTPUT (USED BY THE MANUFACTURER)

12 24V DC SUPPLY INPUT (USED BY THE MANUFACTURER)





THE MESUTRONIC GERÄTEBAU GMBH IS A GLOBALLY ACTIVE COMPANY IN THE FIELD OF INDUSTRIAL METAL DETECTION TECHNOLOGY WITH HEADQUARTERS IN GERMANY.

A TEAM OF SPECIALISTS FOCUSES FOR DECADES SUCCESSFULLY ON THE DEVELOPMENT, MANUFACTURING AND DISTRIBUTION OF ELECTRONIC METAL DETECTORS AND SEPARATORS FOR ALL INDUSTRIES. DAILY WE TAKE UP THE CHALLENGE TO SOLVE INDIVIDUAL PROBLEMS RELIABLE AND TAILORED TO THE CUSTOMER. WHERE OTHERS SAID "NO" LONG AGO OUR TASK JUST STARTS. TRUE TO THE MOTTO: "NOTHING IS IMPOSSIBLE."

THOUSANDS OF DETECTOR COILS, VARIOUS TRANSMITTERS AND A VARIETY OF EJECTORS AND MECHANICAL COMPONENTS CAN BE COMBINED DEPENDING ON THE TASK AND SERVE AS A BASIS FOR PRACTICAL AND FLEXIBLE SOLUTIONS. THROUGH YEARS OF CLOSE COLLABORATION WITH OUR CUSTOMERS FROM VARIOUS INDUSTRIES, WE HAVE SHAPED OUR EQUIPMENT PROGRAM CONTINUAL WITH THE RESULT THAT ALL MESUTRONIC PRODUCTS ARE NOW LEADING THE WAY IN PERFORMANCE, QUALITY, RELIABILITY AND HANDLING.

IN ADDITION, OUR WORLDWIDE SALES AND SERVICE NETWORK ENSURES THAT ON ALL CONTINENTS OF THE WORLD A PROFESSIONAL COMPETENT CONTACT PERSON IS AVAILABLE FOR YOU.

**MESUTRONIC**

*Metal Detection made in Germany*

MESUTRONIC Gerätebau GmbH • Hackenfeld 13 • D-94259 Kirchberg, Wald  
Tel.: +49- (0)9927 / 9410-0 • Fax: +49- (0)9927 / 1732  
E-Mail: sales@mesutronic.de • www.mesutronic.de